

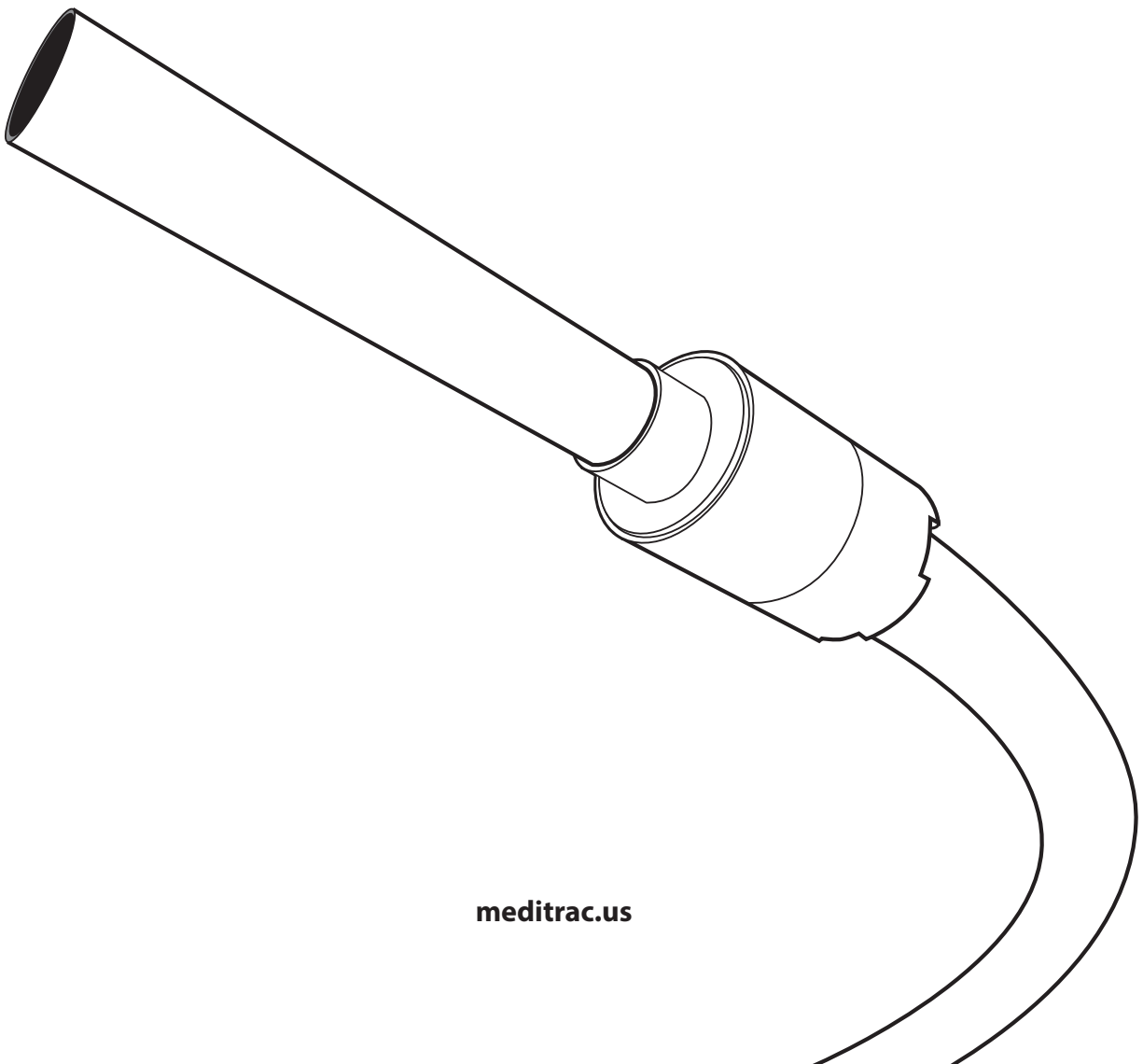

# DESIGN & INSTALLATION INSTRUCTIONS

**MediTrac<sup>®</sup> Medical Gas Piping System**



[meditrac.us](http://meditrac.us)

# Contents

- 1. User Warnings
- 2. Material Description
- 3. Material Use and Limitations
- 4. Description of System and Components
- 5. Installation Practices
- 6. Fitting Assembly
- 7. Capacity Tables

## 1.0 User Warnings

Each installer must meet applicable qualifications in accordance with requirements as established by the administrative authority that enforces the health care facilities codes where medical gas piping is installed. The MediTrac® Corrugated Medical Tubing (CMT) must only be installed by a valid ASSE 6010 or equivalent certified installer who has been successfully trained through the MediTrac® CMT installation program by a factory authorized trainer.

This guide must be used in conjunction with health care facilities codes. Applicable codes will take precedence in the event of a conflict between these instructions and the code. In the absence of codes, installation must be in accordance with the current edition of the Health Care Facilities code, NFPA 99 or Medical Gas Pipeline Systems, CSA Z7396.1:22 if applicable.

In addition to compliance with codes, sound engineering principles and practices must be exercised for the proper design of medical gas piping systems. The installation instructions and procedures contained in these Design & Installation Instructions must be strictly followed. All installations must pass inspections by the authority having jurisdiction prior to occupancy of the serviced areas of the health care facility. These instructions may be updated periodically. Installers must use the most current version which is available at <https://meditrac.us>.

## DANGER

**IF THIS SYSTEM IS USED OR INSTALLED IMPROPERLY, LIFE SUSTAINING / LIFE SUPPORT EQUIPMENT MAY BE IMPAIRED, LEADING TO POSSIBLE SEVERE MEDICAL COMPLICATIONS AND DEATH. APPLICABLE LOCAL CODES AND THESE INSTALLATION INSTRUCTIONS MUST BE STRICTLY FOLLOWED.**

1. Applicable Codes and Standards

### Model Codes:

NFPA-99 2018 Health Care Facilities Code  
CSA Z7396.1:22 Medical Gas Pipeline Systems

### Standard:

UL 1365 UL Outline of Investigation for Corrugated Medical Tubing (CMT) Systems

### Listings:

UL:



### UL Through Penetration Systems:

**W-L-1604**

**C-AJ-1751**

*(see Appendix A for details)*

### ICC

**Seismically Qualified per ICC-ES AC156  
Testing Protocol per ICC-ES ESR-4565**



### Quality Management System:

The Quality Management System for Meditrac is certified to the ISO 9001:2015.

## 2.0 Material Description

The MediTrac® CMT consists of corrugated copper alloy tubing and non-removable mechanically axially swaged brass fittings. Fittings are supplied in a variety of transition connections for easy attachment to traditional copper tube systems and direct connection to piping system components.

Tubing is jacketed with fire-retardant plenum-rated polyethylene which enhances the mechanical properties of the copper alloy tubing and provides protection for the tubing when routing through building components. The jacket is marked at two-foot (0.6 meters) intervals with the manufacturer’s trademark, part number, maximum operating pressure and the length measurements.

## 3.0 Material Use and Limitations

These installation instructions are intended to aid the medical gas pipeline installer in the design, installation, and testing of corrugated medical tubing systems for hospitals and healthcare buildings. All medical gas piping systems must be installed per NFPA 99 or CSA Z7396.1:22 if applicable —this guide provides additional information for clarification. MediTrac® CMT must be installed in accordance with the installation practices and procedures included in the MediTrac® Design and Installation Guide, by a valid ASSE 6010 or equivalent certified installer, who has completed the MediTrac® installer training from a factory authorized trainer. Manufacturer’s training on the proper installation of MediTrac® CMT does not qualify the installer as a ASSE 6010 certified installer—it only demonstrates that the installer has been trained on the proper installation procedure for MediTrac® CMT.

Some of the special features of the MediTrac® CMT are outlined below and in Table 1.

1. MediTrac® CMT is used to provide safe, efficient, and timely installation in buildings such as hospitals, urgent care facilities, laboratories, or other facilities requiring medical grade piping.
2. MediTrac® CMT will be routed in the same locations that traditional copper gas piping materials are installed (i.e., plenum areas, within conduit, along or through floor joists, or in ceiling spaces).

3. For retrofit installations, MediTrac® CMT will be installed anywhere copper pipe has traditionally been installed. It has the benefit of reducing installation time and reducing or eliminating hot work (permitting, etc.), because MediTrac can be supplied in long continuous lengths, reducing the risk of possible leak paths due to the reduction in number of intermediate joints.

## 4.0 Description of System and Components

1. Material for corrugated medical tubing conforms to ASTM B103, copper alloy UNS No. C51000.
2. Jacket is, plenum rated, fire retardant polyethylene tested in accordance to ASTM E-84 with a maximum 25 Flame Spread/50 Smoke Density rating.
3. Fittings are brass metallic copper alloy No. CA 360, cleaned to CGA G4.1, and compliant with NFPA 99 requirements.

FIGURE 1

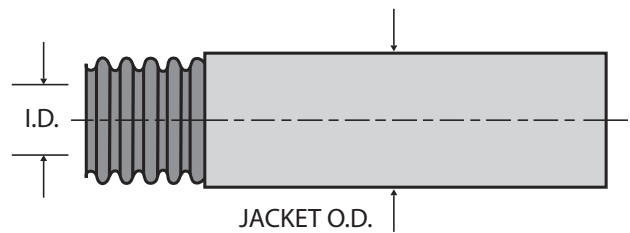

TABLE 1 - TUBING DIMENSIONS IMPERIAL

MediTrac® Size	1/2" (15mm)	3/4" (22mm)	1" (28mm)	1-1/2" (40mm)	2" (50mm)
Corrugated Tubing ID (nominal)	0.599" (15.2mm)	0.820" (20.8mm)	1.060" (26.9mm)	1.525" (38.7mm)	2.060" (52.3mm)
Jacket OD (nominal)	0.875" (22.2mm)	1.125" (28.6mm)	1.375" (34.9mm)	2.125" (53.9mm)	2.625" (66.7mm)

## 5.0 Installation Practices

Precautions must be taken to ensure that any exposed CMT is not damaged or abused during building construction. All system hardware should be stored in a secure, dry location prior to installation.

1. When MediTrac® is installed underground or in a concrete slab, piping will be encased in a nonmetallic sleeve. Suggested minimum nonmetallic conduit sizes in Table 2.

**TABLE 2 - SUGGESTED MINIMUM NONMETALLIC CONDUIT SIZES IMPERIAL**

MediTrac® Size	1/2" (15mm)	3/4" (22mm)	1" (28mm)	1-1/2" (40mm)	2" (50mm)
Conduit Size	1-1/2" (381mm)	2" (50.8mm)	3" (76.2mm)	4" (101.6mm)	6" (152.4mm)

2. MediTrac® CMT is approved for use with non-flammable medical gases and medical support gases up to a max operating pressure of 185psi (12.76 bar). Both the MediTrac® tubing and fittings have been tested to be leak-free at pressure 3.5x greater than the maximum operating pressure of the system 647psi (44.64 bar).
3. MediTrac® CMT is approved for use in Medical-Surgical Vacuum Systems and WAGD Systems. MediTrac® shall not be used for dental vacuum systems that convey fluids through the pipeline or vacuum exhaust applications.
4. MediTrac® CMT shall only use components provided by Flex-Trac, Inc., for use with the MediTrac® CMT.
5. Ends of the piping are to be temporarily capped, plugged, or taped closed prior to installation and routing to prevent the entrance of dirt and/or other debris.
6. BENDING: Undue stress or strain on the tubing or fittings is to be avoided. Tight bends can restrict the gas flow and increase pressure drop. The tightest bend allowed for each size of MediTrac® CMT is shown in Table 3.

**TABLE 3 - RECOMMENDED BEND RADIUS (R) IMPERIAL**

MediTrac® Size	1/2" (15mm)	3/4" (22mm)	1" (28mm)	1-1/2" (40mm)	2" (50mm)
Recommended Bend Radius (inches)	6" (153mm)	8" (204mm)	10" (254mm)	24" (610mm)	30" (762mm)

**FIGURE 1**

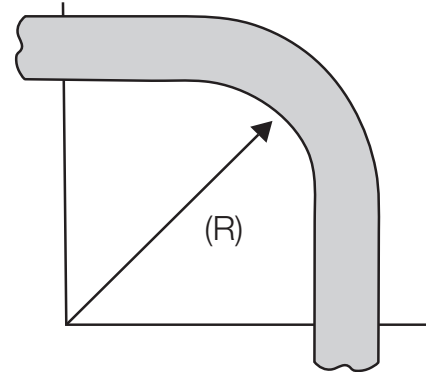

7. MediTrac® CMT shall be supported from the building structure in a manner acceptable by code. Hangers and supports shall comply with MSS SP-58, Pipe Hangers and Supports or equivalent—Materials, Design, Manufacture, Selection, Application, and Installation. Supports for MediTrac® CMT shall be sized for copper tubing. MediTrac® CMT will use the next size up copper pipe hanger to accommodate MediTrac®'s outside diameter (1/2" (15mm) MediTrac® uses 3/4" (22mm) copper pipe hanger). Maximum support spacing is defined in Table 4.

**TABLE 4 - SUPPORT INTERVALS IMPERIAL**

MediTrac® Size	1/2" (15mm)	3/4" (22mm)	1" (28mm)	1-1/2" (40mm)	2" (50mm)
Copper Tube Size for Hanger	3/4" (22mm)	1" (28mm)	1-1/4" (32mm)	2" (54mm)	2-1/2" (65mm)
Maximum Spacing (m)	6' (1.8m)	7' (2.1m)	8' (2.4m)	10' (3.0m)	10' (3.0m)

8. When MediTrac® fittings are installed outdoors fittings shall be wrapped/protected in a manner adequate to prevent exposure to the elements.
9. When MediTrac® is installed outdoors in a non metallic conduit the ends of the conduit shall be sealed to prevent the entrance of water and debris after installation.

## 6.0 Fitting Assembly

### 1. CUT-TO-LENGTH:

Determine the proper length of MediTrac® CMT. Cut through the exterior jacket and copper corrugated tubing using a tubing cutter with an oversized sharp wheel. Use full circular strokes in one direction and tighten roller pressure roughly  $\frac{1}{4}$  turn per revolution.

### ⚠ CAUTION

**FOR YOUR PERSONAL SAFETY—KNIFE BLADE AND CUT TUBE ENDS ARE BOTH SHARP. USE CARE WHEN CUTTING THE JACKET AND HANDLING THE TUBE. TAKE CARE TO ONLY SCORE THE MEDITRAC JACKET. IT IS NOT NECESSARY TO CUT ALL THE WAY THROUGH THE JACKET TO REMOVE. IMPROPER SCORING OF THE JACKET CAN LEAD TO DAMAGE OF THE COPPER ALLOY CORE.**

**DO NOT OVERTIGHTEN CUTTER:**  
OVER TIGHTENING CUTTER MAY CAUSE DEFORMATION TO THE COPPER ALLOY TUBING AND CAUSE ISSUES DURING FITTING ASSEMBLY.

### ⚠ NOTICE

**DUE TO THE LARGE DIAMETER AND DEPTH OF CORRUGATION, TUBING MUST BE CUT WITH A STANDARD TUBING CUTTER RIDGID™ 151/153 OR EQUAL USING A MEDITRAC® CUTTING WHEEL NO. MT-E-5272.**

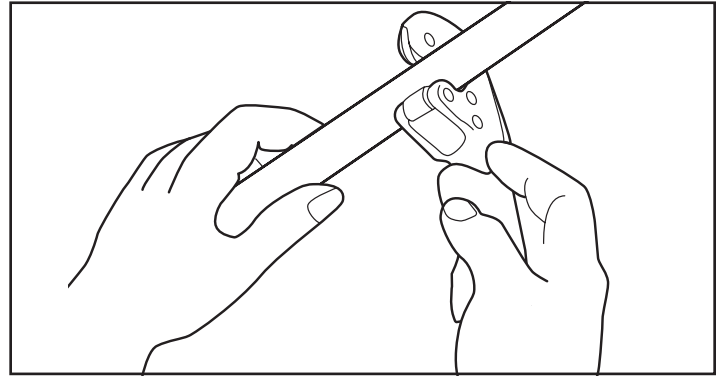

### 2. STRIP JACKET:

Using a MediTrac® jacket stripper (MT-JST) or utility knife, score the jacket approximately 3" (76mm) back from the end. Using pliers or similar tool, pinch the jacketing material on either side of the score mark to remove. Care must be taken when scoring the jacket to prevent damage to the copper alloy core. When using the MediTrac® jacket stripping tool set the blade depth so it only scores the jacket. It does not need to cut all the way through the jacket material.

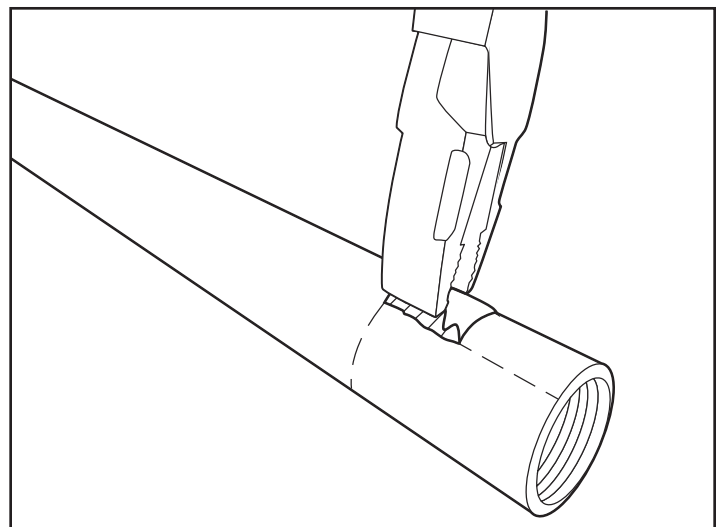
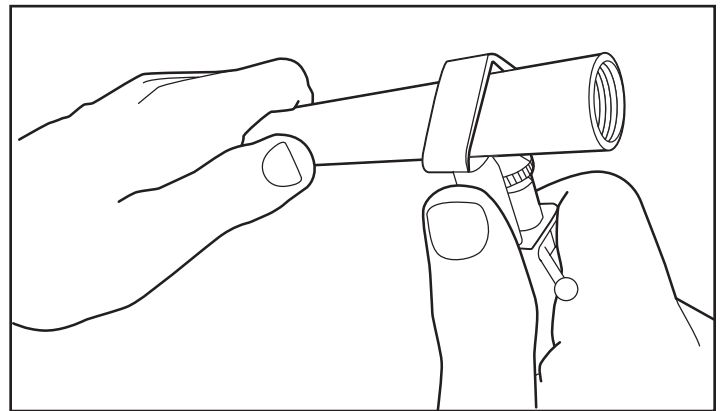

### 3. PRECISION CUT:

Using a tubing cutter with MediTrac® cutting wheel, make final cut exposing six full corrugations (counted on tops of corrugation). Cut must be aligned in the root between two corrugations. Use full circular strokes in one direction and tighten roller pressure slightly after each revolution. Visually inspect finished cut to ensure an even cut free from burrs and/or tears. In the event of an unacceptable cut remove additional jacket material and re-cut leaving six full corrugations exposed.

**DO NOT OVERTIGHTEN ROLLER. BE SURE TO WIPE CLEAR ANY RESIDUAL COPPER PARTICLES FROM CUTTING.**

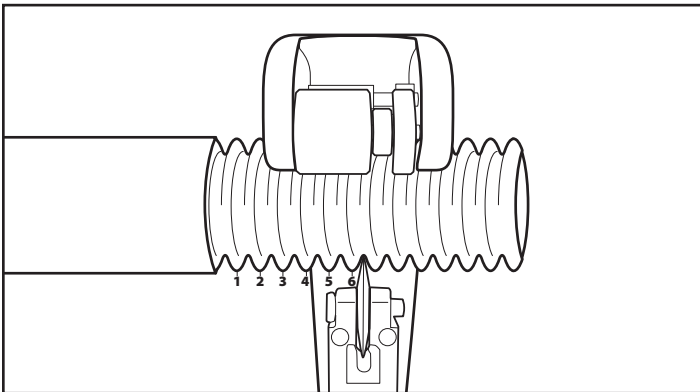

### 4. MECHANICALLY AXIALLY SWAGE FITTING INSTALLATION:

Remove fitting from packaging and remove the threaded axial swaging tool from the fitting assembly. Take care not to drop the two split-rings—an oxygen compatible grease has been applied to the split-rings to help prevent them from falling during disassembly. Slide the axial swaging tool assembly over the tubing and place the split-ring into the first corrugation closest the cut end of the tubing, then slide the swaging assembly over the split-ring to hold them in place. At this time the adapter should be joined to the traditional piping system or outlet using approved methods.

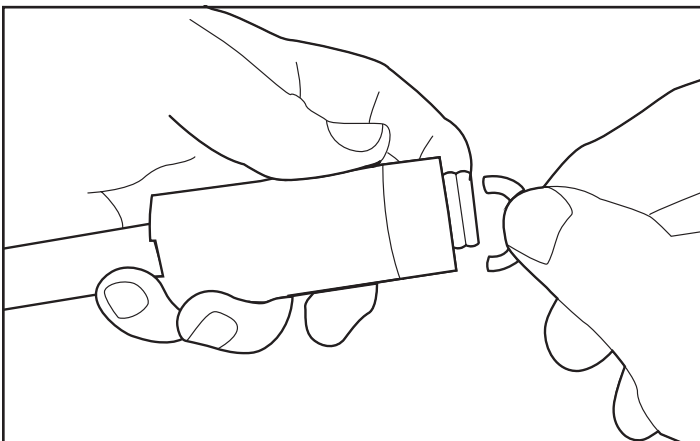

- Once the adapter is installed, thread the axial swaging assembly onto the adapter and tighten using the appropriate wrenches on the wrench flats located on the brass swaging tool. Tighten the swaging tool until the tightening torque increases greatly. See Table 4 or 5 for minimum assembly torque requirements.
- It is recommended that the system be low pressure tested at 50 to 55 psi (3.4 to 3.8 bar) prior to proceeding to the next step.

**TABLE 5 - FITTING TORQUE IMPERIAL**

MediTrac® Size	CMT Designator	Torque Value
1/2" (15mm)	MT-0500-CMT	42 ft-lbs 57 Nm
3/4" (22mm)	MT-0750-CMT	45 ft-lbs 61 Nm
1" (28mm)	MT-1000-CMT	75 ft-lbs 102 Nm
1-1/2" (40mm)	MT-1500-CMT	200-250 ft-lbs 271 Nm to 339 Nm
2" (50mm)	MT-2000-CMT	300-350 ft-lbs 407 Nm to 475 Nm

### 7. AXIALLY SWAGED JACKET LOCK AND ANTI-TAMPER SLEEVE INSTALLATION:

Turn the MediTrac® threaded driver down by hand until resistance is met, using the special MediTrac® driver wrench continue engaging the anti-tamper sleeve until it has covered the adapter wrench flats. Maximum test pressure shall not exceed 1.5x rated max operating pressure 278 psi (19.14 bar).

#### **▲ CAUTION**

**THE FITTING CANNOT BE TIGHTENED ADDITIONALLY OR REMOVED FOR REUSE ONCE THE ANTI-TAMPER SLEEVE IS ENGAGED.**

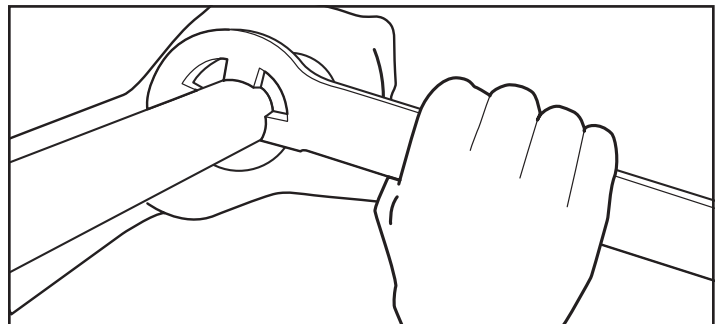

# 7.0 Capacity Tables Imperial

## MediTrac® Flow Capacities in SCFM

Supplied Gas: Medical Air Supply Pressure (PSIG): 55 Pressure Drop (PSIG): 1  
Length (ft)

	10	20	30	40	50	60	75	100	150	200	250	300	400	500
1/2	15.4	11.0	9.0	7.8	7.0	6.4	5.8	5.0	4.1	3.6	3.2	2.9	2.6	2.3
3/4	33.8	24.5	20.3	17.7	16.0	14.7	13.2	11.6	9.6	8.4	7.6	6.9	6.1	5.5
1	61.1	43.9	36.2	31.6	28.4	26.0	23.4	20.4	16.8	14.7	13.2	12.1	10.5	9.5
1-1/2	175.7	128.6	107.2	94.2	85.2	78.5	71.0	62.4	52.0	45.7	41.3	38.1	33.5	30.3
2	353.4	259.0	216.0	189.8	171.8	158.3	143.2	125.9	104.9	92.2	83.5	76.9	67.6	61.2

Supplied Gas: Medical Air Supply Pressure (PSIG): 55 Pressure Drop (PSIG): 2  
Length (ft)

	10	20	30	40	50	60	75	100	150	200	250	300	400	500
1/2	21.5	15.4	12.6	11.0	9.8	9.0	8.1	7.0	5.8	5.0	4.5	4.1	4.1	3.2
3/4	46.7	33.8	28.0	24.5	22.1	20.3	18.3	16.0	13.2	11.6	10.4	9.6	9.6	7.6
1	85.1	61.1	50.4	43.9	39.5	36.2	32.6	28.4	23.4	20.4	18.3	16.8	16.8	13.2
1-1/2	239.9	175.7	146.4	128.6	116.4	107.2	97.0	85.2	71.0	62.4	56.5	52.0	52.0	41.3
2	482.3	353.4	294.7	259.0	234.4	216.0	195.4	171.8	143.2	125.9	113.9	104.9	104.9	83.5

Supplied Gas: Medical Air Supply Pressure (PSIG): 55 Pressure Drop (PSIG): 3  
Length (ft)

	10	20	30	40	50	60	75	100	150	200	250	300	400	500
1/2	26.2	18.7	15.4	13.4	12.0	11.0	9.8	8.6	7.0	6.1	5.5	5.0	4.4	3.9
3/4	56.3	40.8	33.8	29.6	26.6	24.5	22.1	19.3	16.0	14.0	12.6	11.6	10.1	9.1
1	103.2	74.2	61.1	53.3	47.9	43.9	39.5	34.4	28.4	24.7	22.2	20.4	17.8	16.0
1-1/2	287.8	210.8	175.7	154.4	139.6	128.6	116.4	102.3	85.2	74.9	67.7	62.4	54.8	49.6
2	578.4	423.9	353.4	310.7	281.1	259.0	234.4	206.0	171.8	151.0	136.6	125.9	110.6	100.1

Supplied Gas: Medical Air Supply Pressure (PSIG): 55 Pressure Drop (PSIG): 4  
Length (ft)

	10	20	30	40	50	60	75	100	150	200	250	300	400	500
1/2	30.1	21.5	17.7	15.4	13.8	12.6	11.3	9.8	8.1	7.0	6.3	5.8	5.0	4.5
3/4	64.4	46.7	38.6	33.8	30.5	28.0	25.2	22.1	18.3	16.0	14.4	13.2	11.6	10.4
1	118.4	85.1	70.1	61.1	55.0	50.4	45.3	39.5	32.6	28.4	25.5	23.4	20.4	18.3
1-1/2	327.6	239.9	199.9	175.7	158.9	146.4	132.4	116.4	97.0	85.2	77.1	71.0	62.4	56.5
2	658.0	482.3	402.1	353.4	319.8	294.7	266.6	234.4	195.4	199.4	155.4	143.2	125.9	113.9

Supplied Gas: Medical Air Supply Pressure (PSIG): 55 Pressure Drop (PSIG): 5  
Length (ft)

	10	20	30	40	50	60	75	100	150	200	250	300	400	500
1/2	33.5	24.0	19.7	17.1	15.4	14.1	12.6	11.0	9.0	7.8	7.0	6.4	5.6	5.0
3/4	71.5	51.8	42.9	37.5	33.8	31.0	28.0	24.5	20.3	17.7	16.0	14.7	12.8	11.6
1	131.7	94.6	78.0	68.0	61.1	56.1	50.4	43.9	36.2	31.6	28.4	26.0	22.7	20.4
1-1/2	362.1	265.2	221.0	194.2	175.7	161.8	146.4	128.6	107.2	94.2	85.2	78.5	69.0	62.4
2	727.3	533.0	444.4	390.6	353.4	325.7	294.7	259.0	216.0	189.8	171.8	158.3	139.1	125.9

### Conversion Factors:

	SG	Multiplier
Medical Air	1.0000	1.0000
Oxygen (O2)	1.1044	0.9535
Nitrogen (N2)	0.9669	1.0153
Carbon Dioxide (CO2)	1.5189	0.8110
Nitrous Oxide (N2O)	1.5300	0.8085

NOTE: Multiply the value given in the flow capacity tables by the multiplier shown for the gas being used to correct flow capacity.

**MediTrac® Pressure Drop per Foot – Vacuum (inHg)**

SCFM	3/4"	1"	1-1/2"	2"
1	0.001	0.0004		
2	0.005	0.002	0.001	
3	0.013	0.004	0.003	
4	0.024	0.008	0.005	0.001
5	0.039	0.012	0.009	0.002
6	0.058	0.018	0.013	0.003
7	0.080	0.025	0.018	0.004
8	0.107	0.033	0.024	0.005
9	0.138	0.043	0.032	0.007
10	0.173	0.053	0.040	0.008
11		0.065	0.050	0.010
12		0.078	0.060	0.012
13		0.092	0.072	0.015
15		0.125	0.099	0.021
20			0.188	0.039

For additional vacuum pressure drop assistance contact MediTrac® for technical support.

**APPENDIX A**  
**UL CLASSIFICATION**  
**Through-penetration Firestop Systems**

**SYSTEM NO. W-L-1604**

ANSI/UL1479 (ASTM E814)	CAN/ULC S115
F Rating — 1 Hr	F Rating — 1 Hr
T Rating — 3/4 Hr	FT Rating — 3/4 Hr
	FH Rating — 1 Hr
	FTH Rating — 3/4 Hr

**1. Wall Assembly** - The 1 hr fire-rated gypsum board/stud wall assembly shall be constructed of the materials and in the manner specified in the individual U300, U400, V400 or W400 series Wall and Partition Design in the UL Fire Resistance Directory and shall include the following construction features:

**A. Studs** - Wall framing may consist of either wood studs or steel channel studs. Wood studs to consist of nom 2 by 4 in. (51 by 102 mm) lumber spaced 16 in. (406 mm) OC. Steel studs to be min 3-5/8 in. (92 mm) wide and spaced max 24 in. (610 mm) OC.

**B. Gypsum Board\*** - Min 5/8 in. (16 mm) thick, 4 ft (1.2 m) wide with square or tapered edges as specified in the individual Wall and Partition Design. Max diam of opening is 4 in. (102 mm).

**2. Through Penetrating Product\*** - CMT — One nom 2 in. (51 mm) diam (or smaller) semi-rigid copper alloy medical tubing to be installed either concentrically or eccentrically within the firestop system. The annular space shall be min 1/4 in. (6 mm) to max 1-1/8 in. (28.6 mm). Tubing to be rigidly supported on both sides of wall assembly.

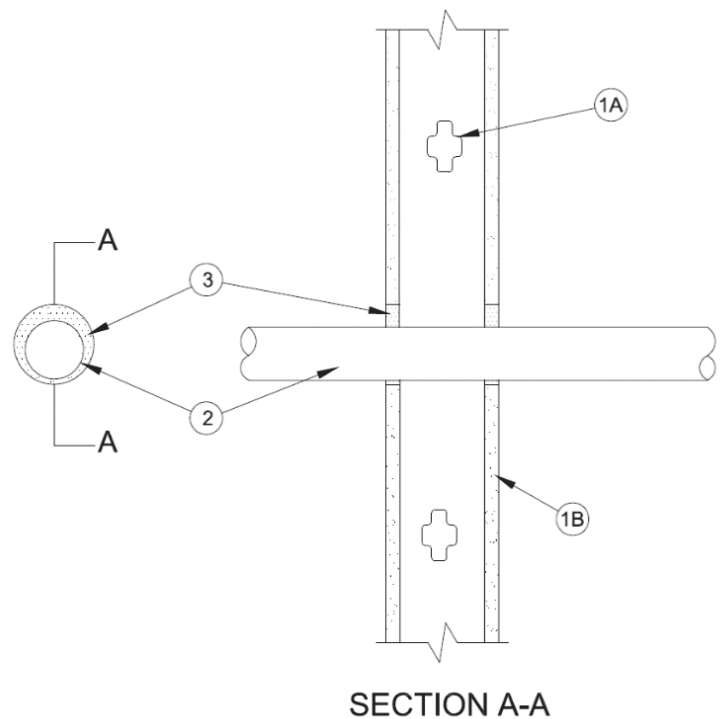

**Flex-Trac, Inc.**— MediTrac® Corrugated Medical Tubing

**3. Firestop System** - The firestop system shall consist of the following:

**A. Fill, Void or Cavity Material\*** — Caulk — Min 5/8 in. (16 mm) thickness of fill material applied within the annulus, flush with both surfaces of wall.

**RECTORSEAL** — Metacaulk 1000

\* Indicates such products shall bear the UL or cUL Certification Mark for jurisdictions employing the UL or cUL Certification (such as Canada), respectively.

**UL CLASSIFICATION**  
**Through-penetration Firestop Systems**

**SYSTEM NO. C-AJ-1751**

ANSI/UL1479 (ASTM E814)	CAN/ULC S115
F Rating — 1 Hr	F Rating — 1 Hr
T Ratings — 3/4 and 1 Hr (See Item 2)	FT Ratings — 3/4 and 1 Hr (See Item 2)
	FH Rating — 1 Hr
	FTH Ratings — 3/4 and 1 Hr (See Item 2)

**1. Floor or Wall Assembly** - Min 4-1/2 in. (114 mm) thick floor, or min 5-1/8 in. (130 mm) thick wall, constructed of reinforced lightweight or normal weight (100-150 pcf or 1600-2400 kg/m<sup>3</sup>) concrete. Wall may also be constructed of any UL Classified **Concrete Blocks**\*. Max diam of opening is 4 in. (102 mm).

See **Concrete Blocks** (CAZT) category in the Fire Resistance Directory for names of manufacturers.

**2. Through Penetrating Product\*** - CMT — One nom 2 in. (51 mm) diam (or smaller) semi-rigid copper alloy medical tubing to be installed either concentrically or eccentrically within the firestop system. The annular space shall be min 1/4 in. (6 mm) to max 1-1/8 in. (28.6 mm). Tubing to be rigidly supported on both sides of floor or wall assembly.  
**The T, FT and FTH Ratings are 1 hr except that for tubing exceeding nom 1 in. (25 mm) diam, the T, FT and FTH Ratings are 3/4 hr.**

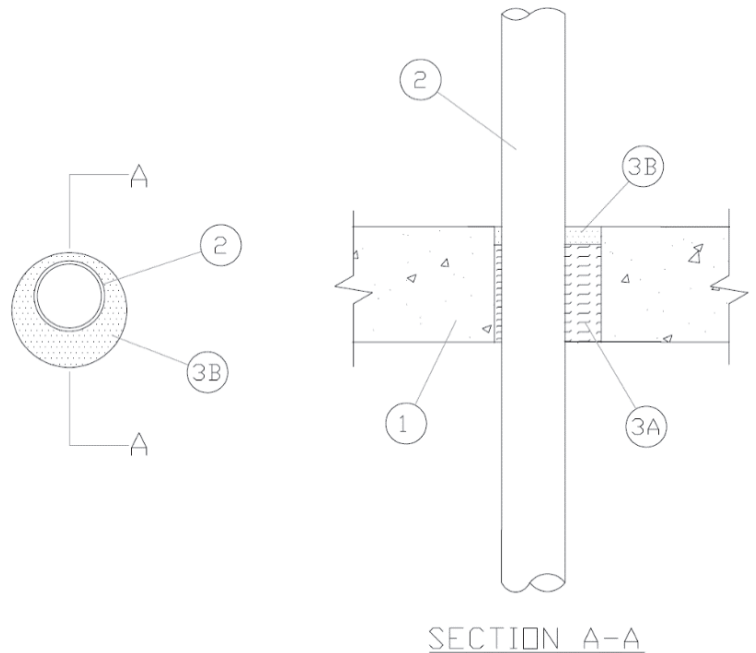

**Flex-Trac, Inc.**— MediTrac® Corrugated Medical Tubing

**3. Firestop System** - The firestop system shall consist of the following:

**A. Packing Material** — Min 3-7/8 in. (98.4 mm) thickness of min 4 pcf (64 kg/m<sup>3</sup>) mineral wool batt insulation firmly packed into opening as a permanent form. Packing material to be recessed from top surface of floor or from both surfaces of wall as required to accommodate the required thickness of fill material.

**B. Fill, Void or Cavity Material\* — Caulk** — Min 5/8 in. (16 mm) thickness of fill material applied within the annulus, flush with top surface of floor or with both surfaces of wall.

**RECTORSEAL** — Metacaulk 1000

\* Indicates such products shall bear the UL or cUL Certification Mark for jurisdictions employing the UL or cUL Certification (such as Canada), respectively.





**Flex-Trac, Inc.**  
427 Creamery Way  
Exton Pa, 19341  
1.610.524.7272  
info@meditrac.us  
meditrac.us

**meditrac.us**